

# Galanz

@2021 Galanz Americas Limited Company

# Galanz

MODEL: GLEC02RDRE14  
RETRO ESPRESSO MAKER USER MANUAL



Thank you for purchasing a Galanz product. Please read this manual carefully for correct usage and safety, and keep for future reference. For service, support and warranty information, call 800-562-0738.

@2021 Galanz Americas Limited Company

# CONTENTS

<b>Important Safeguards</b> .....	<b>1</b>
<b>Getting To Know Your Espresso Maker</b> .....	<b>3</b>
Main Unit	
Control Panel	
<b>Preparing &amp; Using Your Espresso Maker</b> .....	<b>4</b>
Before first use	
Espresso making guide	
<b>Cleaning &amp; Maintenance</b> .....	<b>5</b>
<b>Trouble Shooting</b> .....	<b>6</b>
<b>Product Warranty</b> .....	<b>7</b>

# IMPORTANT SAFEGUARDS

When using electrical appliances, basic safety precautions should always be followed, including the following:

## READ ALL INSTRUCTIONS BEFORE USING YOUR Galanz Espresso Maker.

- Close supervision is necessary when any appliance is used by or near children or individuals with certain disabilities.
- To protect against electric shock, DO NOT PLACE ANY PART OF THE ESPRESSO MAKER IN WATER OR OTHER LIQUIDS.
- Do not operate the appliance without water in the water tank.
- Scalding may occur if the basket holder is opened during the brewing cycle.
- Do not let cord hang over edge of table or counter, or touch hot surfaces.
- Do not operate the appliance with a damaged cord, plug, after the appliance malfunctions or after it has been dropped or damaged in any manner. Please contact us at 1-800-562-0738 for troubleshooting and warranty support.
- The use of accessory attachments not recommended by Galanz may cause injuries.
- Unplug from outlet when the appliance is not in use and before cleaning. Allow it to cool before putting on or taking off parts, and before cleaning the appliance. To unplug, grasp the plug and pull from the outlet. Never pull from the power cord.
- Do not clean with metal scouring pads. Pieces can break off the pad and touch electrical parts, posing a risk of electric shock.
- Do not use outdoors.
- Do not use appliance for other than intended use.
- This appliance is for HOUSEHOLD USE ONLY.
- Do not touch hot surfaces. Use handles and knobs.
- This appliance can be used by persons (including children) with reduced physical, sensory or mental capabilities or lack of experience and knowledge if they have supervision or instruction concerning use of the appliance in a safe way and understand the hazards involved.
- Children should not play with the appliance.
- For appliance with type Y attachment, if the supply cord is damaged, it must be replaced by the manufacturer, its service agent or similarly qualified person in order to avoid a hazard.

# IMPORTANT SAFEGUARDS

- Do not place on or near a hot gas or electric burner, or in a heated oven.
- Appliances are not intended to be operated by an external timer or separate remote-control system.
- **WARNING: Risk of Fire or Electric Shock.** Do not remove the bottom cover. No user serviceable parts inside. Repair should be done by authorized service personnel only.
- Avoid contacting moving parts.

Model No.	GLEC02RDRE14
Power Consumption	120V, 60Hz
Watts	1350W
Capacity	2 cups

**HOUSEHOLD USE ONLY  
SAVE THESE INSTRUCTIONS**

# GETTING TO KNOW YOUR ESPRESSO MAKER

# PREPARING & USING YOUR ESPRESSO MAKER

## MAIN UNIT

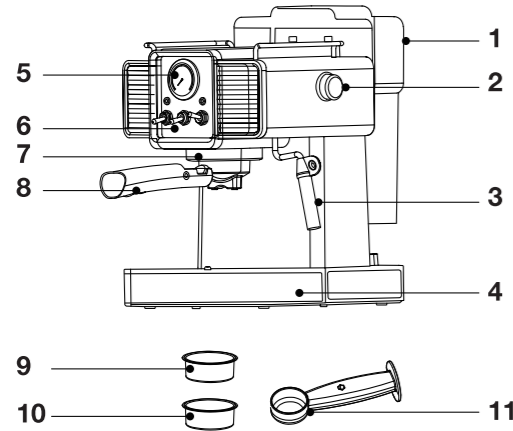

### 1. Removable Water Tank :

For easy filling or discarding.

### 2. Steam/Hot Water Dial:

To release steam or hot water.

### 3. Steam Wand

### 4. Removable Drip Tray:

For easy cleaning.

### 5. Pressure Meter:

For visibly monitoring the pressure level.

### 6. Control Panel

### 7. Group Head:

For easy positioning of the portafilter.

### 8. Portafilter

### 9. 1-Cup Filter Basket

### 10. 2-Cup Filter Basket

### 11. Scoop and Tamper

## CONTROL PANEL

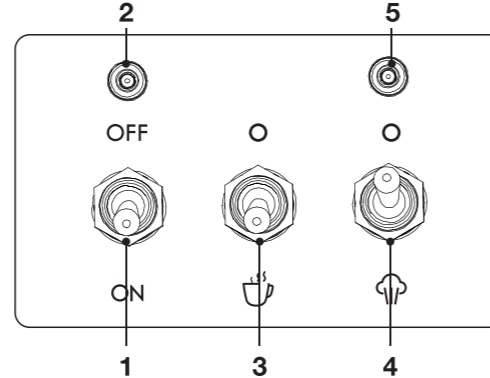

### 1. Power Switch :

Flip down to power-on the machine.

### 2. ON/OFF Light

### 3. Espresso Switch:

Flip down to extract espresso.

### 4. Steam Switch:

Flip down to heat up water and generate steam

### 5. Steam/Hot Water Light

## BEFORE FIRST USE

### MACHINE PREPARATION

- Ensure all packaging has been removed.
- Position the machine onto a dry, stable, flat & horizontal countertop.
- Clean parts and accessories (water tank, portafilter, filter baskets and steam wand) using warm water and a gentle dishwashing liquid and rinse well. Wipe the outer housing and drip tray with a soft damp cloth and dry thoroughly. Do not immerse the outer housing, power cord or power plug in water or any other liquid.

### INITIAL START UP

- Fill tank with water. Water level should not exceed the "MAX" mark on the tank.
- Insert the Power Plug into a 120V AC power outlet & switch the power on.
- When the ON/OFF light is illuminated, the machine is ready to use.
- Insert the filter basket in the portafilter, insert the portafilter flat against the group head, and turn the portafilter right all the way to the center position.

### FLUSHING THE MACHINE

- It is recommended to complete a water flushing operation, without ground coffee, to ensure the machine has been conditioned.
- Flip down the Espresso Switch, water should start flowing from the portafilter. Allow water to run through until it stops.

## ESPRESSO MAKING GUIDE

### FILL THE WATER TANK

- Open the water tank lid and pour cold, preferably filtered water into the tank to the maximum mark on the side of the tank and slide the water tank back into position at the back of the machine.

#### NOTE:

Check the water level before using the machine and replace the water daily. The water tank should be filled with fresh, cold tap water before each use. Do not use de-mineralized or distilled water or any other liquid.

### PREHEAT THE MACHINE

- Switch the power on by flipping the Power Switch down, the ON/OFF LIGHT will illuminate & pulse to indicate the thermoblock is heating up. When the ON/OFF light stops flashing, the machine is ready to use.

### COFFEE DOSE AND TAMPING

- Wipe the filter basket with a dry cloth before using to remove any remaining coffee grounds.
- Measure out enough coffee beans for 1 or 2 cups of espresso (depending on your needs) then grind the beans in a coffee grinder until they are a fine powder. You can also use pre-ground coffee beans that have been ground for an espresso maker. Fill the filter basket with the desired amount of coffee grounds.

#### NOTE:

For a balanced taste we recommend using 8-10g of coffee grounds for 1 cup and 15-18g of coffee grounds for 2 cups.

- Tap the portafilter several times to distribute the coffee evenly in the filter basket.

# PREPARING & USING YOUR ESPRESSO MAKER

- Tamp down firmly using the other end of the measuring scoop (using approx.30-40lbs or 15-20kg of pressure). It's important to apply consistent pressure every time.
- Wipe excess coffee from the rim of the filter basket to ensure a proper seal in the group head is achieved.

## EXTRACTING ESPRESSO

- Insert the Portafilter into the Group Head & lock into position. Place an espresso cup centered below the portafilter on the drip tray.
- Flip the Espresso Switch down. A pumping noise will be heard. After a few seconds, espresso will begin to brew into the cup.
- When sufficient espresso has been extracted, flip the Espresso Switch up to 'Standby'. This will stop the flow of espresso. We recommend approx. 30 sec of extraction.

### NOTE:

For optimal flavor when making 1 cup of espresso, you should extract approx. 1 oz. When making 2 cups of espresso, you should extract approx. 2 oz.

## FROTHING MILK

- Flip the Power and Steam Switches ON. Both lights will start to flash indicating that the machine is heating up. When both lights stop flashing, the steam is ready.
- It is recommended to purge the steam wand before inserting it into the milk. Put the steam wand into an empty pitcher, turn the Steam/Hot water Dial counterclockwise to purge the steam wand. Discard any liquid that was purged into the pitcher.
- Add milk to a mug or frothing pitcher, making sure to only fill half way or less so that the milk has room to froth without over flowing.
- Insert the wand into the milk and turn the Steam/Hot water Dial counterclockwise.

- To stop the steam turn the Steam/Hot water Dial to the 'OFF' position and remove the steam wand from the mug or pitcher.

### NOTE:

The steam function should only be used when the wand is inserted in milk. The steam should always be turned off before removing the wand from the container of milk.

## HOT WATER

- Flip the Power Switch on and wait till the power light stays illuminated.
- Place the steam wand into an empty mug. Turn the Steam/Hot water Dial counterclockwise. Hot water will come out from the Steam Wand.
- Turn the Steam/Hot water Dial to OFF to stop Hot Water function.

### NOTE:

Steam and Hot Water functions cannot be operated at the same time.

# MAINTENANCE & TROUBLE SHOOTING

## CLEANING & MAINTENANCE

### CLEANING THE STEAM WAND

- Run steam to clear milk from wand after frothing.
- Allow the steam wand to cool completely before touching or removing any parts.
- Remove the steam wand and clean it under running water after each use

### CLEANING FILTER BASKET

- Discard any used coffee grounds from the portafilter after each use. Be careful to only discard the coffee grounds and not the filter basket.
- Place the filter into the portafilter. Run water through the machine with the filter and portafilter in place without any ground coffee.

### CLEANING THE OUTER HOUSING

- The outer housing and can be cleaned with a soft, damp cloth, and polish with a soft, dry cloth. Do not use abrasive cleaners, pads or cloths which can scratch the surface.

### CLEANING THE DRIP TRAY

- We recommend removing, emptying and cleaning the drip tray after each use. Wash the drip tray with warm soapy water, using a non-abrasive washing liquid, rinse and dry thoroughly. The drip tray base and cover are dishwasher safe.

### NOTE:

Do not immerse power cord, power plug or appliance in water or any other liquid.

## TROUBLE SHOOTING

PROBLEM	POSSIBLE CAUSE	WHAT TO DO
Not enough espresso is being extracted	Too much ground coffee in the filter basket	Recommend using 8-10g of coffee grounds for 1 cup and 15-18g of coffee grounds for 2 cup
	Coffee tamped too firmly	Recommend using approx. 30-40lbs or 15-20kg of pressure
Too much water is being extracted, espresso is light in color and weak tasting.	Not enough coffee grounds in filter basket	Recommend dosing 8-10g of coffee grounds for 1 cup and 15-18g of coffee grounds for 2 cup
	Coffee not tamped firmly enough	Recommend using approx. 30-40lbs or 15-20kg of pressure
Machine is making pulsing /pumping sound while extracting espresso and frothing milk	The machine is carrying out the normal operation of the thermoblock system and 15 bar pump.	No action required as this is the normal operation of the machine
Espresso runs out around the edge of the portafilter	Portafilter is not inserted into the group head properly	Insert portafilter into the group head and align with 'LOCK' on the group head collar, until resistance is felt. Refer to 'EXTRACTING ESPRESSO', page 5.
	There are coffee grounds around the filter basket rim	Clean any excess ground coffee from the rim of the filter basket to ensure a proper fit into the group head.
	Too much ground coffee in the filter basket	Recommend using 8-10g of coffee grounds for 1 cup and 15-18g of coffee grounds for 2 cup
	Coffee tamped too firmly	Recommend using approx. 30-40lbs or 15-20kg of pressure
Machine is making a loud and continuous pumping noise	Water tank is empty or not securely in place	Refer to 'FILL THE WATER TANK' on page 4

# PRODUCT WARRANTY

This warranty applies to products sold by Galanz Americas in the U.S. This warranty is in lieu of any other warranty and expressly applies to the individual product only.

Galanz product is warranted for one year following purchase for defects in material and workmanship. **Please save your receipt as proof of purchase is required to make a warranty claim.** During this warranty period, we will provide the replacement cost of this product, a replacement or the equivalent, or repair per our discretion.

The warranty cannot be transferred through resale, including the resale through a 3rd party unauthorized retailer and is only bestowed upon the original consumer purchaser upon purchase from an authorized retailer.

■ **This warranty does not cover and excludes damage or defects caused by:**

- Consumer misuse
- Abuse
- Neglect including the failure to clean and/or provide adequate regular maintenance as outlined in the user manual
- Commercial use
- Subjecting the product to any voltage outside the specified range
  - Loss of parts
- The affixing of any attachments not provided with the product
- Accident, or
- Use in a manner not intended and outlined in the user manual.
- Any subsequent damages caused by the above listed exclusions will not be covered and any claims determined to meet the

above exclusions will be denied. All liability is limited to the purchase price and does not include any:

- Retail offered extended warranties
- Tax
- Other charges (including postage to send required materials)
- Incidental and/or consequential damages associated with the product in question.

Every implied warranty, including any statutory warranty of merchantability or fitness for a particular purpose is disclaimed except to the extent prohibited by law, in which case such warranty is limited to the duration of this written warranty. This warranty gives you specific legal rights. You may have other legal rights that vary depending on where you live. Some states do not allow limitations on implied warranties or special, incidental, or consequential damages, so the above limitations may not apply to you.

If you have a claim under this warranty, please call our Customer Service number: 1-800-562-0738.

For faster service, please have the model number, serial number, and receipt ready for the operator to assist you.

# WARRANTY REGISTRATION

Please mail this warranty card to address below within 30 days of purchase.

**Galanz Americas, 55 Challenger Road, Suite 503, Ridgefield Park, NJ 07660.**

**PLEASE PRINT CLEARLY.**

Name \_\_\_\_\_

Address \_\_\_\_\_

City \_\_\_\_\_ State \_\_\_\_\_ Postal Code \_\_\_\_\_

Phone \_\_\_\_\_ Email \_\_\_\_\_

Model Number \_\_\_\_\_ Serial Number \_\_\_\_\_

Purchase Location \_\_\_\_\_

**You must attach a copy of your purchase receipt to validate your registration.**