

Galanz

User Manual

Model# GL1FR24ASSAGN



Thank you for purchasing a Galanz product. Please read this manual carefully for correct usage and safety, and keep for future reference. For service, support and warranty information, call 800-562-0738.

CONTENT

| | |
|---|-----------|
| RANGE SAFETY | 2 |
| The Anti-tip Bracket | 2 |
| IMPORTANT SAFETY INSTRUCTIONS..... | 3 |
| PARTS AND FEATURES | 6 |
| CONTROL PANEL | 8 |
| COOKTOP USE | 9 |
| Ignition and Operation of the Burners | 9 |
| Cookware | 10 |
| OVEN USE | 11 |
| Cooking with the Gas Oven | 11 |
| Oven Tips and Techniques..... | 12 |
| RANGE CARE | 14 |
| Cleaning | 14 |
| TROUBLESHOOTING | 17 |
| Baking and Roasting Problems..... | 17 |
| Cooktop | 18 |
| Oven | 19 |
| LIMITED WARRANTY | 20 |
| WARRANTY REGISTRATION | 21 |

RANGE SAFETY

RANGE SAFETY

Your safety and the safety of others are very important.

We have provided many important safety messages in this manual and on your appliance. Always read and obey all safety messages.



This is the safety alert symbol. This symbol alerts you to potential hazards that can kill or hurt you and others. All safety messages will follow the safety alert symbol and either the word “DANGER,” “WARNING” or “CAUTION.” These words mean:



An imminently hazardous situation. You could be

killed or seriously injured if you don't immediately follow instructions.



A potentially hazardous situation which, if not avoided, could result in death or serious bodily injury.



A potentially hazardous situation which, if not avoided, may result in moderate or minor injury.

All safety messages will tell you what the potential hazard

is, tell you how to reduce the chance of injury, and tell you what can happen if the instructions are not followed.

THE ANTI-TIP BRACKET

⚠ WARNING



Tip Over Hazard

A child or adult can tip the range and be killed. Connect anti-tip bracket to rear range foot. Reconnect the anti-tip bracket, if the range is moved. See the installation instructions for details. Failure to follow these instructions can result in death or serious burns to children and adults.

Making sure the anti-tip bracket is installed:

- Slide range forward.
- Look for the anti-tip bracket securely attached to floor.
- Slide range back so rear range foot is under anti-tip bracket.

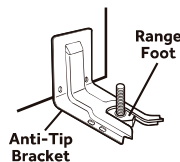

RANGE SAFETY

IMPORTANT SAFETY INSTRUCTIONS

WARNING: To reduce the risk of fire, electrical shock, injury to persons, or damage when using the range, follow basic precautions, including the following:

- **WARNING:** TO REDUCE THE RISK OF TIPPING OF THE RANGE, THE RANGE MUST BE SECURED BY PROPERLY INSTALLED ANTI-TIP DEVICES. TO CHECK IF THE DEVICES ARE INSTALLED PROPERLY, SLIDE RANGE COMPLETELY FORWARD, LOOK FOR ANTI-TIP BRACKET SECURELY ATTACHED TO THE FLOOR BEHIND THE RANGE AND SLIDE RANGE COMPLETELY BACK UNTIL THE REAR RANGE FOOT IS UNDER ANTI-TIP BRACKET.
- **WARNING:** NEVER use this appliance as a space heater to heat or warm the room. Doing so may result in carbon monoxide poisoning and overheating of the oven.
- **WARNING:** NEVER cover any slots, holes or passages in the oven bottom or cover an entire rack with materials such as aluminum foil.

Doing so blocks airflow through the oven and may cause carbon monoxide poisoning. Aluminum foil linings may also trap heat, causing a fire hazard.

- **CAUTION:** Do not store items of interest to children in cabinets above a range or on the back guard of a range – children climbing on the range to reach items could be seriously injured.
- Do Not Leave Children Alone – Children should not be left alone or unattended in area where the range is in use. They should never be allowed to sit or stand on any part of the range.
- Wear Proper Apparel – Loose-fitting or hanging garments should never be worn while using the range.
- User Servicing – Do not repair or replace any part of the range unless specifically recommended in the manual. All other servicing should be referred to a qualified technician.
- Storage in or on the Range – Flammable materials should not be stored in an oven or near surface units.
- Do Not Use Water on Grease Fires – Smother fire or flame

READ AND SAVE THESE INSTRUCTIONS

RANGE SAFETY

- or use dry chemical or foam-type extinguisher.
- Use Only Dry Potholders – Moist or damp potholders on hot surfaces may result in burns from steam. Do not let potholder touch hot heating elements. Do not use a towel or other bulky cloth.
- DO NOT TOUCH SURFACE UNITS OR AREAS NEAR UNITS – Surface units may be hot even though they are dark in color. Areas near surface units may become hot enough to cause burns. During and after use, do not touch, or let clothing or other flammable materials contact surface units or areas near units until they have had sufficient time to cool. Among those areas are the cooktop and surfaces facing the cooktop.
- Never Leave Surface Units Unattended at High Heat Settings – Boil over causes smoking and greasy spillovers that may ignite.
- Glazed Cooking Utensils – Only certain types of glass, glass/ceramic, ceramic, earthenware, or other glazed utensils are suitable for range-top service without breaking due to the sudden change in temperature.
- Utensil Handles Should Be Turned Inward and Not Extend Over Adjacent Surface Units – To reduce the risk of burns, ignition of flammable materials, and spillage due to unintentional contact with the utensil, the handle of a utensil should be positioned so that it is turned inward, and does not extend over adjacent surface units.
- Clean Cooktop With Caution – If a wet sponge or cloth is used to wipe spills on a hot cooking area, be careful to avoid steam burn. Some cleaners can produce noxious fumes if applied to a hot surface.
- Use Care When Opening Door – Let hot air or steam escape before removing or replacing food.
- Do Not Heat Unopened Food Containers – Build-up of pressure may cause container to burst and result in injury.
- Keep Oven Vent Ducts Unobstructed.
- Placement of Oven Racks – Always place oven racks in desired location while oven is cool. If rack must

READ AND SAVE THESE INSTRUCTIONS

RANGE SAFETY

be moved while oven is hot, do not let potholder contact hot heating element in oven.

- **DO NOT TOUCH HEATING ELEMENTS OR INTERIOR SURFACES OF OVEN** –Heating elements may be hot even though they are dark in color. Interior surfaces of an oven become hot enough to cause burns. During and after use, do not touch, or let clothing or other flammable materials contact heating elements or interior surfaces of oven until they have had sufficient time to cool. Other surfaces of the appliance may become hot enough to cause burns – among these surfaces are oven vent openings and surfaces near these openings, oven doors, and windows of oven doors.
- **Proper Installation** – The range, when installed, must be electrically grounded in accordance with local codes or, in the absence of local codes, with the National Electrical Code, ANSI/NFPA 70. In Canada, the range must be electrically grounded in accordance with Canadian Electrical Code. Be sure the range is properly installed and grounded by a qualified technician.

- Disconnect the electrical supply before servicing the appliance.
- Injuries may result from the misuse of appliance doors or drawers such as stepping, leaning, or sitting on the doors or drawers.
- **Maintenance** – Keep range area clear and free from combustible materials, gasoline, and other flammable vapors and liquids.
- Top burner flame size should be adjusted so it does not extend beyond the edge of the cooking utensil.

For self-cleaning ranges –

- **Do Not Clean Door Gasket** –The door gasket is essential for a good seal. Care should be taken not to rub, damage, or move the gasket.
- **Do Not Use Oven Cleaners** – No commercial oven cleaner or oven liner protective coating of any kind should be used in or around any part of the oven.
- **Clean Only Parts Listed in Manual.**

For units with ventilating hood –

- **Clean Ventilating Hoods Frequently** – Grease should not be allowed to accumulate on hood or filter.
- When flambé cooking under the vent hood, turn the fan on.

READ AND SAVE THESE INSTRUCTIONS

PARTS AND FEATURES

PARTS AND FEATURES

This manual covers several different models. The range you have purchased may have some or all of the items listed. The locations and appearances of the features shown here may not match those of your model.

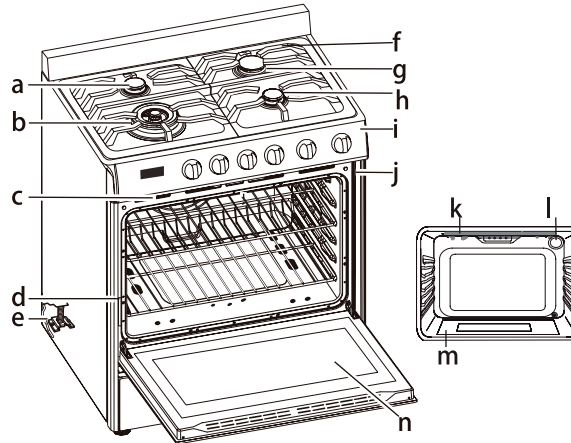

- a. Left Rear Surface Burner
- b. Left Front Surface Burner
- c. Oven Vent
- d. Model and Serial Number Plate
- e. Anti-tip Bracket
- f. Grate
- g. Right Rear Surface Burner

- h. Right Front Surface Burner
- i. Control Panel
- j. Door Gasket
- k. Broil Burner
- l. Oven Light
- m. Bottom Burner (not visible)
- n. Oven Door Window

PARTS AND FEATURES

- a. Control Knob Off Position
- b. Burner Cap
- c. Burner Head
- d. Electrode
- e. Flame Detector (On Some Models)

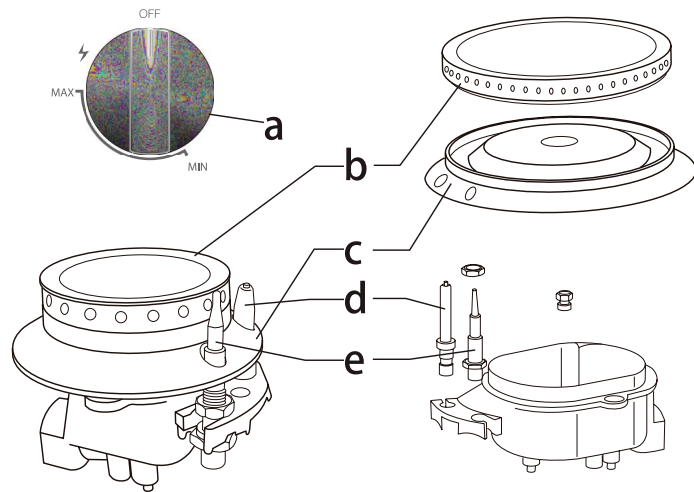

Accessory

Both flat-bottom wok pans and round-bottom wok pans supported with the wok ring (provided) can be used with all models.

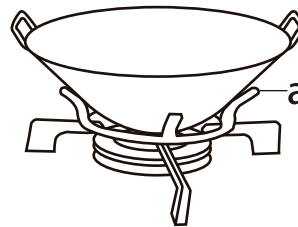

a. Wok Ring

CONTROL PANEL

CONTROL PANEL

24" MODELS

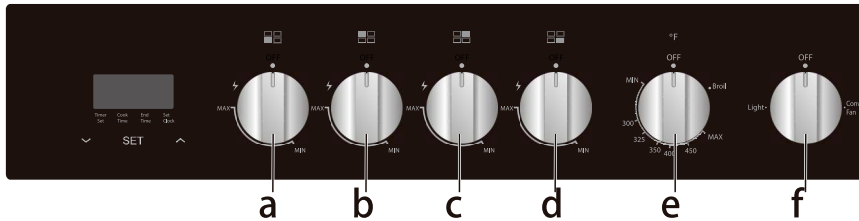

- a. Front Left Burner
- b. Rear Left Burner
- c. Rear Right Burner
- d. Front Right Burner
- e. Temperature Control
- f. Features Control

CLOCK AND TIMER

Your model has a digital display, 12-hour clock with three Control buttons.

IMPORTANT: In the event of a power failure, all settings including the time display will be lost. When the power is returned, the bar above Timer Set and 12:00 will be displayed.

COOKTOP USE

TIME OF DAY

When the power is connected, the screen displays 12:00 and the bar above “Set Clock.”

To set the correct time, press the up arrow or down arrow until the correct time is displayed. After 5 seconds, the clock will start automatically, or you can press the function button to select manual operation.

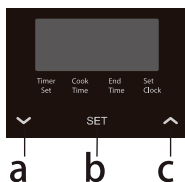

- Decrease Time
- Function
- Increase Time

SET THE TIMER

The digital countdown timer can be set up to 12 hours and 59 minutes maximum.

To set the timer, press the function button repeatedly until the bar above Timer Set is displayed. Once the function button is released, the current time is displayed and the bar above Timer Set flashes. When the function button is pressed the remaining time is displayed. When the set time is reached, Timer Set disappears and the alarm will ring. To stop the alarm, press any button.

NOTE: After pressing the function button, you must set the timer within 5 seconds.

COOKTOP USE

Read the instructions before installing or using this appliance.

- This appliance shall be installed in accordance with the regulations in force and only used in a well-ventilated space.
- The use of a gas-cooking appliance results in the production of heat and moisture in the room in which it is installed. Ensure that the kitchen is well ventilated: keep natural ventilation holes open or install a mechanical ventilation device (mechanical extractor hood).
- Prolonged intensive use of the appliance may call for additional ventilation, for example opening of a window, or more effective ventilation, for example, increasing the level of mechanical ventilation where present.

IGNITION AND OPERATION OF THE BURNERS

In order to ignite a burner, push down on the knob while rotating it counterclockwise, until the knob indicator is aligned with the ignite icon ⚡.

For models with a safety valve - Once the flame is lit, hold the knob depressed for about 3-4 seconds until the device keeps the burner automatically lit. If the burner fails to ignite, wait one minute for the gas to dissipate before attempting to reignite. Adjust the flame intensity by rotating the knob counterclockwise from MAX (maximum) to MIN (minimum).

To turn off the burner, rotate the knob clockwise until the indicator on the knob is aligned with OFF.

COOKTOP USE

POWER FAILURE

In case of prolonged power failure, the surface burners can be lit manually. Hold a lit match near a burner and turn knob counterclockwise until the indicator is aligned with MAX. After the burner is lit, turn knob to desired setting.

In the case of unintentional flame extinguishing, the safety valve intervenes by shutting off the gas to the burners.

The electric igniter must not be actuated for longer than 15 seconds. Should the burner not light, or should the burner be unintentionally turned off, immediately close the burner, and wait at least 1 minute before repeating. Once ignited, adjust the flame as desired.

For lower gas consumption and a better result, use saucepans with a diameter matching the diameter of the burner, to avoid the flame coming up around the sides of the saucepan. See the Container Table. Use only flat-bottomed pans.

As soon as liquid starts to boil, turn the flame down to a level sufficient to maintain boiling.

COOKWARE

MATCH PAN DIAMETER TO FLAME SIZE

The flame should be the same size as the bottom of the pan or smaller. Do not use small pans with high flame settings as the flames can lick up the sides of the pan. Oversize pans that span two burners are placed front to rear, not side to side.

USE BALANCED PANS

Pans must sit level on the cooktop grate without rocking. Center the pan over the burner.

USE A LID THAT FITS PROPERLY

A well-fitting lid helps shorten the cooking time. Flat, heavy bottom pans provide even heat and stability.

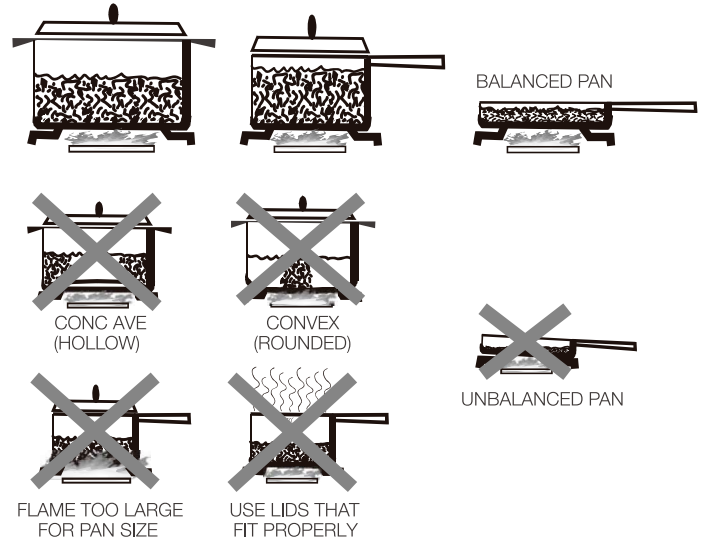

OVEN USE

CONTAINER TABLE

| Burner | Min Saucepan | Max Saucepan |
|-------------|---------------|---------------|
| Auxiliary | 3.5" (9.0 cm) | 6.3" (16 cm) |
| Semi-rapid | 5.1" (13 cm) | 7.1" (18 cm) |
| Rapid | 5.9" (15 cm) | 10.2" (26 cm) |
| Triple ring | 8.3" (21 cm) | 10.2" (26 cm) |

OVEN USE

COOKING WITH THE GAS OVEN

BAKING AND ROASTING

This oven features a gas burner located under the oven cavity which provides evenly distributed heat from the bottom of the oven. The heat rises naturally to bake food evenly.

The heated air circulating naturally, cooks meats to a flavorful, crispiness outside while keeping the inside tender and juicy.

BROILING

This oven features a gas burner located at the top of the oven cavity which provides evenly distributed heat from the top of the oven.

The broil burner will remain on until the Oven Control knob is turned to the off position.

TEMPERATURE CONTROL

The Temperature knob is used to select either the Bake or Broil Oven Mode.

BAKE

Push in on the Temperature knob, and then turn the knob counterclockwise to automatically ignite the bake burner. Continue turning the knob to select the required cooking temperature, between MIN (150°F) and MAX.

Oven Control Display

Illuminates when the oven is preheating.

Turns off when the selected cooking temperature has been reached.

BROIL

Push in on the Temperature control knob, and then turn the knob clockwise to automatically ignite the broil burner.

NOTE: The broil burner will remain on until the Temperature control is returned to the OFF position.

OVEN USE

FEATURES CONTROL

Light

The oven cavity light turns ON automatically, when the Bake or Broil function is selected, and remains on during operation.

Conv (Convection) Fan

During convection cooking, the fan provides hot air circulation throughout the oven. The movement of heated air around the food can help to speed up cooking by penetrating the cooler outer surfaces. Food cooks more evenly, browning and crisping outer surfaces while sealing moisture inside.

OVEN TIPS AND TECHNIQUES

Baking is cooking with heated air. The lower bake burner is on which heats the air in the oven cavity, baking the food with naturally circulating hot air currents.

Follow the recipe or convenience food directions for baking temperature, time and rack position. Baking time will vary with the temperature of ingredients and the size, shape and finish of the baking utensil.

General Guidelines

- For best results, bake food on a single rack with at least 1" - 1 1/2" (2,5 - 3 cm) space between utensils and oven walls.
- Use one rack when selecting the bake mode.
- Check for doneness at the minimum time.

- Use metal bake ware (with or without a non stick finish), heatproof glass, glass-ceramic, pottery or other utensils suitable for the oven.
- When using heatproof glass, reduce temperature by 25°F (15°C) from recommended temperature.
- Use baking sheets with or without sides or jelly roll pans.
- Dark metal pans or nonstick coatings will cook faster with more browning. Insulated bake ware will slightly lengthen the cooking time for most foods.
- Do not use aluminum foil or disposable aluminum trays to line any part of the oven. Foil is an excellent heat insulator and heat will be trapped beneath it. This will alter the cooking performance and can damage the finish of the oven.
- Avoid using the opened door as a shelf to place pans.
- See Troubleshooting for tips to Solving Baking and Roasting Problems.

OVEN USE

BAKE CHART

| FOOD ITEM | RACK POSITION | TEMP. °F (°C) (PREHEATED OVEN) | TIME (MIN) |
|---------------------------|---------------|-----------------------------------|------------|
| Cake | | | |
| Cupcakes | 2 | 350 (175) | 19-22 |
| Bundt Cake | 1 | 350 (175) | 40-45 |
| Angel Food | 1 | 350 (175) | 35-39 |
| Pie | | | |
| 2 crust, fresh, 9" | 2 | 375-400 (190-205) | 45-50 |
| 2 crust, frozen fruit, 9" | 2 | 375 (190) | 68-78 |
| Cookies | | | |
| Sugar | 2 | 350-375 (175-190) | 8-10 |
| Chocolate Chip | 2 | 350-375 (175-190) | 8-13 |
| Brownies | 2 | 350 (175) | 29-36 |
| Breads | | | |
| Yeast bread loaf, 9x5 | 2 | 375 (190) | 18-22 |
| Yeast rolls | 2 | 375-400 (190-205) | 12-15 |
| Biscuits | 2 | 375-400 (190-205) | 7-9 |
| Muffins | 2 | 425 (220) | 15-19 |
| Pizza | | | |
| Frozen | 2 | 400-450 (205-235) | 23-26 |
| Fresh | 2 | 475 (246) | 15-18 |

- See Troubleshooting for tips to Solving Baking and Roasting Problems.

ROAST CHART

Roast should typically be 20 minutes per pound at 350°F (175°C).

| MEATS | WEIGHT (lb) | OVEN TEMP. °F (°C) | RACK POSITION | TIME (min. per lb) | INTERNAL TEMP. °F (°C) |
|------------------------------------|-------------|--------------------|---------------|--------------------|---|
| Beef | | | | | |
| Rib Roast | 4-6 | 325 (160) | 2 | 16-20 18-22 | 145 (63) medium rare 160 (71) medium |
| Rib Eye Roast, (boneless) | 4-6 | 325 (160) | 2 | 16-20 18-22 | 145 (63) medium rare 160 (71) medium |
| Rump, Eye, Tip, Sirloin (boneless) | 3-6 | 325 (160) | 2 | 16-20 18-22 | 145 (63) medium rare 160 (71) medium |
| Tenderloin Roast | 2-3 | 400 (205) | 2 | 15-20 | 145 (63) medium rare |
| Pork | | | | | |
| Loin Roast (boneless or bone-in) | 5-8 | 350 (175) | 2 | 16-20 | 160 (71) medium |
| Shoulder | 3-6 | 350 (175) | 2 | 20-25 | 160 (71) medium |
| Poultry | | | | | |
| Chicken whole | 3-4 | 375 (190) | 2 | 18-21 | 180 (82) |
| Turkey, not stuffed | 12-15 | 325 (160) | 1 | 10-14 | 180 (82) |
| Turkey, not stuffed | 16-20 | 325 (160) | 1 | 9-11 | 180 (82) |
| Turkey, not stuffed | 21-25 | 325 (160) | 1 | 6-10 | 180 (82) |
| Turkey Breast | 3-8 | 325 (160) | 1 | 15-20 | 170 (77) |
| Comish Hen | 1-1 1/2 | 350 (175) | 2 | 45-75 total | 180 (82) |
| Lamb | | | | | |
| Half Leg | 3-4 | 325 (160) | 2 | 22-27 28-33 | 160 (71) medium 170 (77) well |
| Whole Leg | 6-8 | 325 (160) | 1 | 22-27 28-33 | 160 (71) medium 170 (77) well |

RANGE CARE

BROIL CHART

| FOOD AND THICKNESS | RACK POSITION | INTERNAL TEMP. °F (°C) | TIME SIDE 1 (MIN.)* | TIME SIDE 2 (MIN.)* |
|-----------------------------|---------------|------------------------|---------------------|---------------------|
| Beef | | | | |
| Steak (1-1/2" or more) | | | | |
| Medium rare | 4 | 145 (65) | 9-12 | 8-10 |
| Medium | 4 | 160 (71) | 11-13 | 10-12 |
| Well | 4 | 170 (77) | 18-20 | 16-17 |
| Hamburgers (more than 1") | | | | |
| Medium | 4 | 160 (71) | 8-11 | 5-7 |
| Well | 4 | 170 (77) | 11-13 | 8-10 |
| Poultry | | | | |
| Chicken Quarters | 4 | 180 (82) | 16-18 | 10-13 |
| Chicken Halves | 3 | 180 (82) | 25-27 | 15-18 |
| Chicken Breasts | 4 | 170 (77) | 13-15 | 9-13 |
| Pork | | | | |
| Pork Chops (1 1/4" or more) | 4 | 160 (71) | 12-14 | 11-13 |
| Sausage - fresh | 4 | 160 (71) | 4-6 | 3-5 |

RANGE CARE

CLEANING

IMPORTANT: Before cleaning, make sure all controls are off and the oven and cooktop are cool. Always follow label instructions on cleaning products. Soap, water and a soft cloth or sponge are suggested first unless otherwise noted. Do not use abrasive cleaning products.

EXTERIOR PORCELAIN ENAMEL SURFACES

Food spills containing acids, such as vinegar and tomato, should be cleaned as soon as the entire appliance is cool. These spills may affect the finish.

Cleaning Method:

Glass cleaner, mild liquid cleaner or nonabrasive scrubbing pad: Gently clean around the model and serial number plate because scrubbing may remove numbers.

EXTERIOR STAINLESS STEEL

NOTE: Do not use soap-filled scouring pads, abrasive cleaners, Cooktop Polishing Cream, steel-wool pads, gritty washcloths or some paper towels. Damage may occur, even with one-time or limited use.

Rub in direction of grain to avoid damaging.

RANGE CARE

Cleaning Methods:

Liquid detergent or all-purpose cleaner: Rinse well with clean water and dry with soft, lint-free cloth.

Stainless Steel Cleaner and Polish

Vinegar for hard water spots

OVEN DOOR EXTERIOR

Cleaning Method:

Glass cleaner and paper towels or nonabrasive plastic scrubbing pad: Apply glass cleaner to soft cloth or sponge, not directly on panel.

PORCELAIN-COATED GRATES AND CAPS

- Clean as soon as cooktop, grates and caps are cool.
- Food spills containing acids, such as vinegar and tomato, should be cleaned as soon as the cooktop grates and caps are cool. These spills may affect the finish.
- To avoid chipping, do not bang grates and caps against each other or hard surfaces such as cast iron cookware.
- Do not reassemble caps on burners while wet.

Cleaning Method:

Nonabrasive plastic scrubbing pad and mildly abrasive cleanser

BURNER SPREADER

Wash the burner spreader frequently with boiling water and

detergent to remove any deposits which could block the flame outlet.

Before reinstalling, dry the burner spreader thoroughly so the burner will ignite properly.

COOKTOP CONTROL KNOBS

- Pull knobs straight away from control panel to remove.
- When replacing knobs, make sure knobs are in the Off position.

Cleaning Method:

Soap and water or dishwasher:

NOTE: Do not use steel wool, abrasive cleansers or oven cleaner. Do not soak knobs.

CONTROL PANEL

Cleaning Method:

Glass cleaner and soft cloth or sponge: Apply glass cleaner to soft cloth or sponge, not directly on panel.

NOTE: Do not use abrasive cleaners, steel-wool pads, gritty washcloths or some paper towels. Damage may occur.

OVEN CAVITY

Food spills should be cleaned when oven cools. At high temperatures, foods react with porcelain, so staining, etching, pitting or faint white spots can result.

RANGE CARE

Cleaning Method:

Mild detergent and warm water.

NOTE: Do not use oven cleaners.

OVEN RACKS AND ROASTING RACKS

Cleaning Method:

Steel-wool pad

BROILER PAN

Cleaning Method:

Mildly abrasive cleanser: Scrub with wet scouring pad.

Solution of $\frac{1}{2}$ cup (125 mL) ammonia to 1 gal. (3.75 L) water: Soak for 20 minutes, and then scrub with scouring or steel-wool pad.

Oven cleaner: Follow product label instructions. Porcelain enamel only, not chrome Dishwasher

TROUBLESHOOTING

TROUBLESHOOTING

BAKING AND ROASTING PROBLEMS

With any oven setting poor results can occur for many reasons other than a malfunction of the oven. Check the chart below for causes of the most common problems. Since the size, shape and material of baking utensils directly affect the baking results, the best solution may be to replace old baking utensils that have darkened and warped with age and use.

| BAKING PROBLEM | CAUSE |
|---------------------------------------|--|
| Food browns unevenly | Oven not preheated Aluminum foil on oven rack or oven bottom Baking utensil too large for recipe Pans touching each other or oven walls |
| Food too brown on bottom | Oven not preheated Using glass, dull or darkened metal pans Incorrect rack position Pans touching each other or oven walls |
| Food is dry or has shrunk excessively | Oven temperature too high Baking time too long Oven door opened frequently Pan size too large |
| Food is baking or roasting too slowly | Oven temperature too low Oven not preheated Oven door opened frequently Tightly sealed with aluminum foil Pan size too small |

| | |
|--|--|
| Piecrusts do not brown on bottom or crust is soggy | Baking time not long enough Using shiny steel pans Incorrect rack position Oven temperature is too low |
| Cakes pale, flat and may not be done inside | Oven temperature too low Incorrect baking time Cake tested too soon Oven door opened too often Pan size may be too large |
| Cakes high in middle with crack on top | Oven temperature too high Baking time too long Pans touching each other or oven walls Incorrect rack position Pan size too small |
| Piecrust edges too brown | Oven temperature too high Edges of crust too thin |

TROUBLESHOOTING

COOKTOP

| PROBLEM | POSSIBLE CAUSE | SOLUTION |
|--|---|--|
| Heating elements and controls do not work. | Fuse is blown or circuit breaker is tripped. No electricity to the cooktop. | Replace the fuse or reset the circuit breaker. If the problem continues, call an electrician. Have electrician check your power supply. |
| Heating elements do not heat properly. | Improper cookware is being used. | Select proper cookware. See "Cookware." If the problem continues, call for service. |
| Heating elements cycle off even when elements are turned to their highest settings. | Heating element temperature limiters are temporarily shutting off the elements due to exceeding the maximum allowable temperature. | This is a normal operating condition, especially during rapid heat-up operations. The element will cycle back on automatically after it has cooled sufficiently. |
| Glass ceramic surface is see through or appears to be red in color. | Under direct or bright lighting, you will sometimes be able to see through the glass and into the chassis due to its transparent quality. You may also notice a red tint under these conditions | These are normal properties of black ceramic glass panels. |

OVEN

TROUBLESHOOTING

TROUBLESHOOTING

| PROBLEM | POSSIBLE CAUSE | SOLUTION |
|--|--|--|
| Oven is not heating | No power to the oven | Replace the fuse or reset the circuit breaker. If the problem continues, call an electrician. |
| | Oven control not turned on | Make sure the oven temperature has been selected. |
| Oven is not cooking evenly | Not using the correct bake ware or oven rack position | Refer to cook charts for recommended rack position. Always reduce recipe temperature by 25 °F(15 °C) when baking with Convention Bake mode. |
| Oven display stays off | Power interruption | Turn off power at the main power supply (fuse or breaker box). Turn breaker back on. If condition persists, call for service. |
| Cooling fan continues to run after oven is turned off | The electronic components have not yet cooled sufficiently | The fan will turn off automatically when the electronic components have cooled sufficiently. |
| Oven light is not working properly | Light bulb loose or burned-out. | Reinsert or replace the light bulb. Touching the bulb with fingers may cause the bulb to burn out. |
| Oven light stays on | Door is not closing completely | Check for obstruction in oven door. Check to see if hinge is bent or door switch broken. |
| Cannot remove lens cover | Soil build-up around the lens cover. | Wipe lens cover area with a clean, dry towel prior to attempting to remove the lens cover. |
| Clock and timer are not working properly | No power to the oven | Check the circuit breaker or fuse box to your house. Make sure there is proper electrical power to the oven. |
| Excessive Moisture | | When using bake mode, preheat the oven first. Convection Bake and Convection Roast will eliminate any moisture in the oven. |
| Porcelain Chips | Porcelain interior is bumped by oven racks | When removing and replacing oven racks, always tilt racks upward and do not force them to avoid chipping the porcelain. |

FOR MORE HELP, VISIT GalanzAMERICA.COM OR CALL THE CONSUMER HELP LINE AT 1-877-337-3639.

LIMITED WARRANTY

IN-HOME SERVICE FULL ONE YEAR WARRANTY

For 12 months from the date of original retail purchase, Galanz will repair or replace any part free of charge including labor that fails due to a defect in materials or workmanship. Galanz may replace or repair at their sole discretion any part, or sub system including the entire product. Product must be accessible, without encumbrance and installed properly to receive warranty repair service.

LIMITED WARRANTY

NOTE: This warranty commences on the date the item was purchased, or ownership assumed from a builder and the original purchase receipt must be presented to the authorized service representative before warranty repairs are rendered.

Exceptions:Commercial Use Warranty

90 days labor from date of original purchase

90 days parts from date of original purchase

No other warranty applies.

FOR WARRANTY SERVICE

All service must be performed by a Galanz authorized service .

For service, please call 1-800-562-0738. Before calling please have available the following information: (a) Model number and serial number of your appliance. (b) The name and address of the dealer you purchased the unit from and the date of purchase. (c) A clear description of the problem. (d) A proof of purchase (sales receipt).

This warranty covers home appliance services within the contiguous United States and where available in Alaska, Hawaii and Puerto Rico.

What is not covered by this warranty:

Replacement or repair of household fuses, circuit breakers, wiring or plumbing. A product whose original serial number has been removed or altered. Any service charges not specifically identified as normal such as normal service area or hours.

Replacement of light bulbs.

Damage to clothing.

Damage incurred in shipping.

Damage caused by improper installation or maintenance.

Damage from misuse, abuse accident, fire, flood, or acts of nature.

Damage from service other than an authorized Galanz dealer or service center.

Damage from incorrect electrical current, voltage or supply.

Damage resulting from any product modification, alteration or adjustment not authorized by Galanz.

Adjustment of consumer operated controls as identified in the owner's manual.

Hoses, knobs, lint trays and all attachments, accessories and disposable parts.

Labor, service transportation, and shipping charges for the removal and replacement of defective parts beyond the initial 12-month period.

Damage from other than normal household use.

Any transportation and shipping charges.

THIS LIMITED WARRANTY IS GIVEN IN LIEU OF ALL OTHER WARRANTIES, EXPRESS ED OR IMPLIED, INCLUDING BUT NOT LIMITED TO, THE WARRANTIES OF MERCHANTABILITY AND FITNESS FOR A PARTICULAR PURPOSE

The remedy provided in this warranty is exclusive and is granted in lieu of all other remedies.

This warranty does not cover incidental or consequential damages, so the above limitations may not apply to you.

Some states do not allow limitations on how long an implied warranty lasts, so the above limitations may not apply to you.

This warranty gives you specific legal rights, and you may have other rights, which vary from state to state.

WARRANTY REGISTRATION

Please mail this warranty card to the address below within 30 days of purchase.
Galanz Americas, 55 Challenger Road, Suite 503, Ridgefield Park, NJ 07660.

PLEASE PRINT CLEARLY.

Name _____

Address _____

City _____ State _____ ZIP _____

Phone _____ Email _____

Model Number _____ Serial Number _____

Purchase Location _____

You must attach a copy of your purchase receipt to validate your registration.

Galanz